

5	6	7	8
DESCRIPTION		APPROVED	DATE
NEW DOCUMENT			
FINS CHANGED TO 0.5MM WITH 2MM PITCH			9/06/2016
		REV.	CHANGE ORDER
		A	
		B	

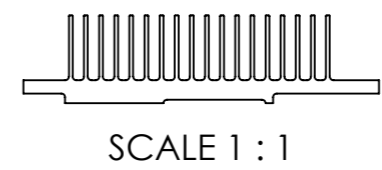
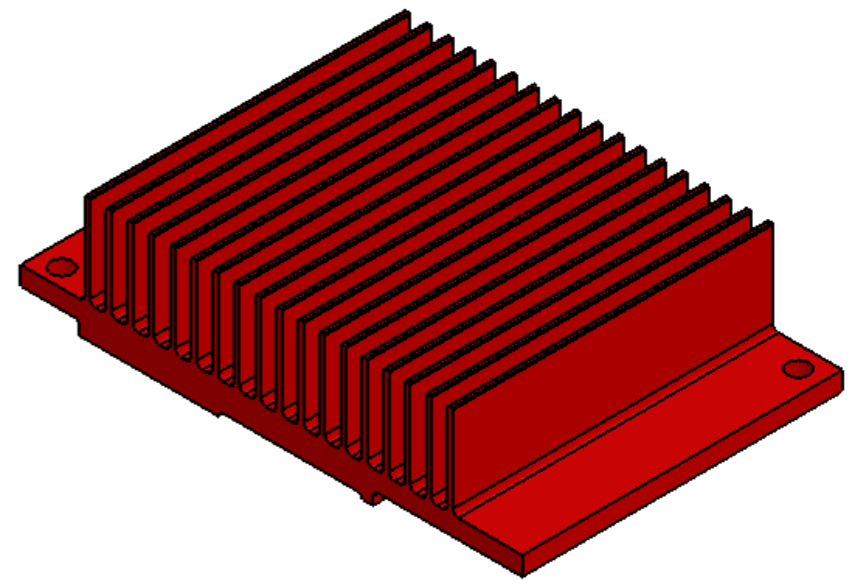
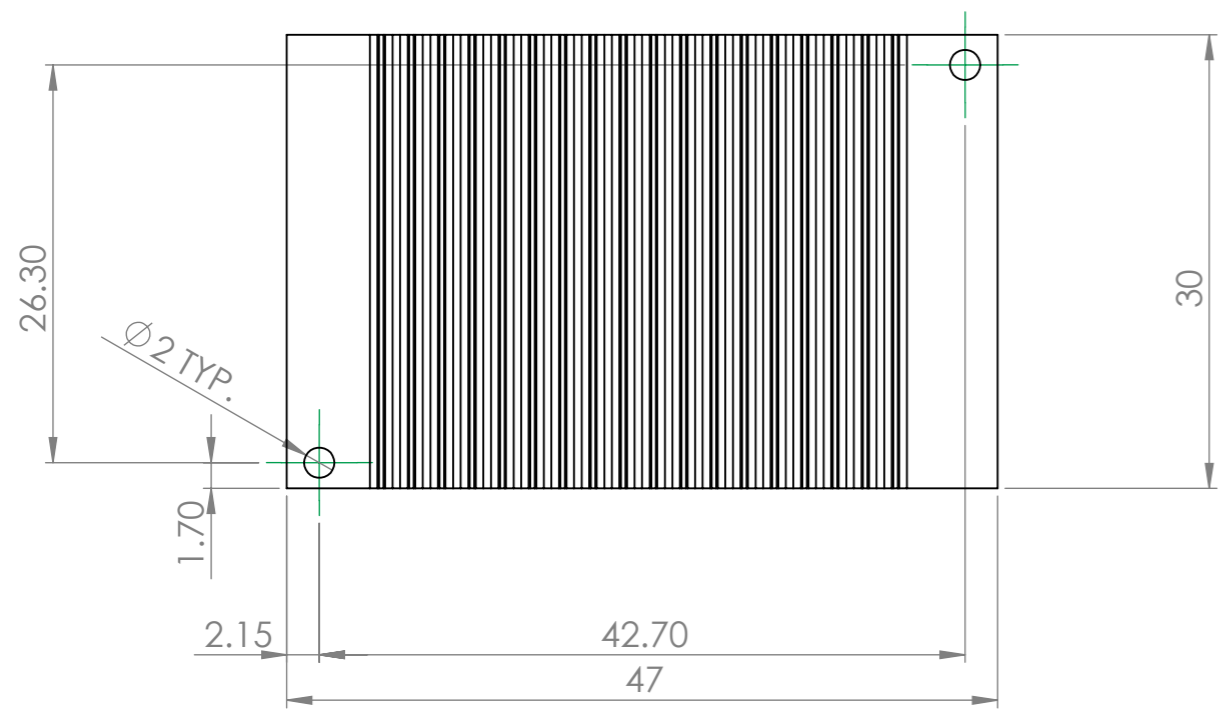
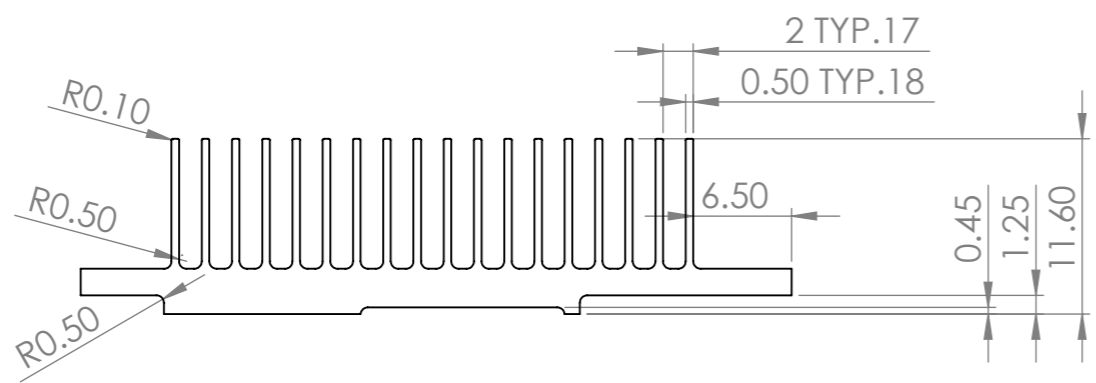
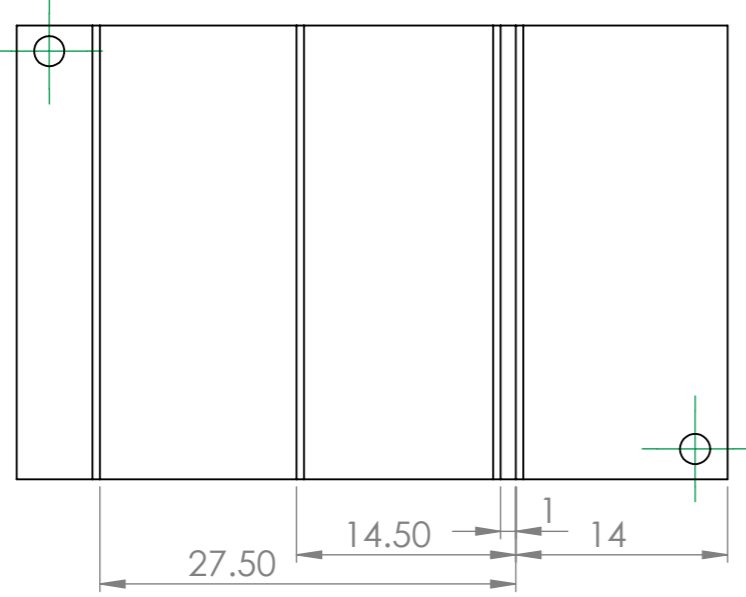

Korat Engineering Ltd. Mobile: 058-4624069
avil@korat-eng.com

DESIGNER	NAME	DATE	SCALE	SURFACE ROUGHNESS	CUSTOMER	PROJECT
Avi Levy	Avi Levy	09-Jun-16	2:1		SolidRun	IMS6 SOM
DRAWING	NAME:				HEATSINK	
Avi Levy	DRAWING NO.				Heatsink for IMS ver1.3 - ver1.4	
09-Jun-16	REV.				DRAWING SIZE	
09-Jun-16	B				A3	
Property of Korat Engineering					SHEET 1 OF 2	

ALL DIMENSIONS ARE IN MILLIMETERS

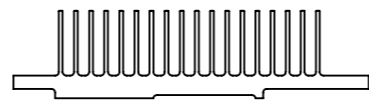

SCALE 1 : 1